

(12) INTERNATIONAL APPLICATION PUBLISHED UNDER THE PATENT COOPERATION TREATY (PCT)

(19) World Intellectual Property Organization  
International Bureau



(43) International Publication Date  
8 November 2001 (08.11.2001)

PCT

(10) International Publication Number  
WO 01/84142 A1

- (51) International Patent Classification<sup>7</sup>: G01N 33/487, 33/50, C12M 1/34
- (74) Agent: ALLMAN, Peter, John; Marks & Clerk, Sussex House, 83-85 Mosley Street, Manchester M2 3LG (GB).
- (21) International Application Number: PCT/GB01/01829
- (81) Designated States (*national*): AE, AG, AL, AM, AT, AU, AZ, BA, BB, BG, BR, BY, BZ, CA, CH, CN, CO, CR, CU, CZ, DE, DK, DM, DZ, EE, ES, FI, GB, GD, GE, GH, GM, HR, HU, ID, IL, IN, IS, JP, KE, KG, KP, KR, KZ, LC, LK, LR, LS, LT, LU, LV, MA, MD, MG, MK, MN, MW, MX, MZ, NO, NZ, PL, PT, RO, RU, SD, SE, SG, SI, SK, SL, TJ, TM, TR, TT, TZ, UA, UG, US, UZ, VN, YU, ZA, ZW.
- (22) International Filing Date: 25 April 2001 (25.04.2001)
- (25) Filing Language: English
- (26) Publication Language: English
- (30) Priority Data: 0009960.6 25 April 2000 (25.04.2000) GB
- (84) Designated States (*regional*): ARIPO patent (GH, GM, KE, LS, MW, MZ, SD, SL, SZ, TZ, UG, ZW), Eurasian patent (AM, AZ, BY, KG, KZ, MD, RU, TJ, TM), European patent (AT, BE, CH, CY, DE, DK, ES, FI, FR, GB, GR, IE, IT, LU, MC, NL, PT, SE, TR), OAPI patent (BF, BJ, CF, CG, CI, CM, GA, GN, GW, ML, MR, NE, SN, TD, TG).
- (71) Applicant (*for all designated States except US*): ONCO-PROBE LIMITED [GB/GB]; The Fairbairn Building, 70-72 Sackville Street, Manchester, M60 1QD (GB).
- (72) Inventors; and
- (75) Inventors/Applicants (*for US only*): EDEN, Robert, David [GB/GB]; 102 Hob Hey Lane, Culcheth, Warrington, Cheshire W13 4NW (GB). WOOLLEY, David, Edward [GB/GB]; 47 Grebe Close, Poynton, Cheshire SK12 1HU (GB).
- Published:  
— with international search report  
— before the expiration of the time limit for amending the claims and to be republished in the event of receipt of amendments

[Continued on next page]

(54) Title: ELECTROCHEMICAL SENSING

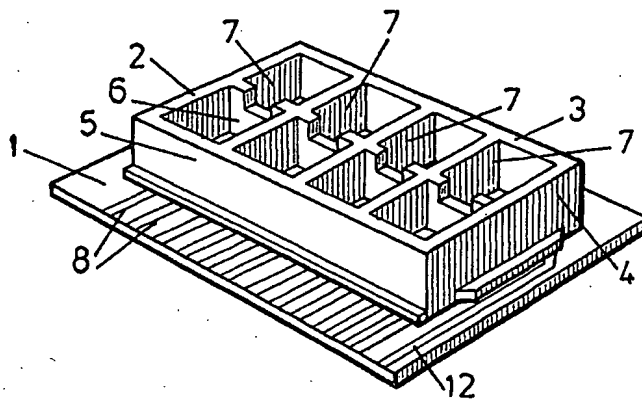

(57) Abstract: An electrochemical sensor and method for using such a sensor to monitor signals generated by biological cells. The sensor comprises a first well for receiving a culture medium including biological cells, the first well including a working electrode a portion of which is exposed to any liquid introduced into the well. The exposed surface is capable of supporting a layer of biological cells. An adjacent second well receives an in situ reference electrode or can receive an inserted electrode, the two wells being separated by a wall. The wall is arranged such that, if the first well is filled with an electrochemically conductive culture medium to a first level sufficient to immerse the working electrode, and the second well is filled with an electrochemically conductive culture medium to a second level, electrochemical continuity is established between the liquids within the wells. The electrochemical activity of cells forming a confluent layer on the working electrode can be determined by monitoring signals developed between the working and reference electrodes. Electrochemical continuity between the working two cells can be achieved in various ways, for example by forming an opening in the wall, e.g. a notch in an upper edge of the wall, or positioning an ion permeable material between the wells. A common reference electrode can be provided in a single second well or extending beneath a series of second wells.

WO 01/84142 A1

BEST AVAILABLE COPY



---

*For two-letter codes and other abbreviations, refer to the "Guidance Notes on Codes and Abbreviations" appearing at the beginning of each regular issue of the PCT Gazette.*

## ELECTROCHEMICAL SENSING

The present invention relates to an electrochemical sensor and a method for monitoring signals generated by biological cells.

US Patent No. 6010889 describes a method and apparatus for assessing the metabolic and behavioural activities of viable cells by monitoring electrochemical signals generated by the cells. A culture medium incorporating cells of interest is introduced into a container so as to immerse the working electrode a portion of which is exposed within the container. The exposed portion of the electrode is covered with a thin film of gold. After the introduction of the culture medium a layer of adherent cells becomes established on the exposed working electrode surface. The working electrode communicates with a reference electrode via an arrangement within the container that provides electrochemical continuity. Detection circuitry is connected to monitor signals appearing between the working and reference electrodes, those signals being representative of processes occurring at the cell surfaces in contact with the working electrode. Analysis of the signals enables assessment of cell behaviour, for example the reaction of the cells to the introduction of a stimulant, suppressant or cytotoxic agent into the container.

The apparatus described in the above US patent functions satisfactorily but is inconvenient for large scale use, for example in comparative studies where several chemical agents or drugs are to be tested on the same cell culture in a speedy and economical manner. In particular, it is not easy to establish electrochemical continuity between a reference electrode and the culture medium within the container.

It is an object of the present invention to provide an improved electrochemical sensor and sensing method which may be applied to establish electrochemical continuity between a reference electrode and a body of culture medium, for example in the circumstances described in the above US patent.

According to the present invention, there is provided an electrochemical sensor comprising at least one first well for receiving a sample of culture medium containing biological cells, a working electrode a portion of which is exposed within the first well and is capable of supporting a layer of biological cells, and at least one second well located adjacent the first and separated therefrom by a wall, the wall

being arranged such that, if the first well is filled with an electrochemically conductive culture medium to a first predetermined level sufficient to immerse the working electrode and the second well is filled with an electrochemically conductive culture medium to a second predetermined level, electrochemical continuity is established between the bodies of liquid within the first and second wells, whereby electrochemical signals generated by cells on the working electrode may be detected by monitoring signals generated between the working electrode and the liquid within the second well.

Preferably, a reference electrode is exposed within the or each second well below the second predetermined level. A single reference electrode may extend beneath an array of second wells. In some applications however electrical continuity between a reference electrode and liquid within the or each second well may be established by immersing the tip of an appropriately-supported reference electrode in that liquid rather than relying upon a reference electrode which is permanently incorporated into the sensor structure.

The invention also provides a method for monitoring signals generated by biological cells, wherein a layer of cells is formed on an exposed portion of a working electrode located within a first sensor well, the first well and an adjacent second well are filled to respective first and second predetermined levels with an electrochemically conductive culture medium, the wells being arranged such that electrochemical continuity is established between the bodies of culture medium in the first and second wells, and electrochemical cell activity is detected by monitoring signals appearing between the working electrode and a reference electrode in contact with culture medium in the second well.

The wall which separates the adjacent first and second wells can be arranged in various different ways to achieve the required electrochemical continuity between culture media within the two wells. For example, the wall may define an opening below the first and second predetermined levels such that bodies of culture medium filling the wells to the predetermined levels are in contact through the opening which may be for example a notch in the top edge of the wall. Alternatively, the wall may define an upper edge which is above the first and second predetermined levels, a liquid-absorbent material extending over the wall upper edge from below the first

predetermined level in the first well to below the second predetermined level in the second well. Culture medium within the wells is absorbed into the material which extends over the upper edge of the wall, electrochemical continuity being achieved via the absorbed liquid. As a further alternative, the wall may define an upper edge above the first and second predetermined levels, the wall including an ion-permeable portion exposed in the first well beneath the first predetermined level and in the second well beneath the second predetermined level. The ion-permeable portion may be formed by adhesive or cement used to secure a lower edge of the wall partitioning to a base of the sensor assembly.

An array of first wells may be provided, each separated from a respective second well by a respective partitioning wall. Alternatively, an array of first wells may be provided with each of the first wells being separated from a common second well by a partitioning wall a portion of which allows electrochemical continuity between opposite sides of the wall.

A plurality of working electrodes may be spaced apart within each of the first wells to enable the comparison of signals generated from nominally identical layers of cells supported on each of the working electrodes within one well. To encourage the formation of cell layers on the working electrodes, exposed portions of the working electrodes may be located at the base of a recess defined by an opening in an insulating layer at the bottom of the first well. The working electrodes could be for example printed on a base board of the sensor assembly, the insulating layer being formed over the printed electrodes except for those portions which are to be exposed. Exposed portions could be given an appropriate electrically conductive surface treatment, for example a gold layer finish which is biocompatible with cell adhesion and growth. The gold layer could be applied to the working electrodes before the deposit of the insulating layer, openings in the insulating layer exposing small areas of the gold layer. Other surface treatments, which could be applied through openings in an insulating layer overlying the working electrodes, and which would facilitate cell attachment to improve the electrochemical signal, could include polylysine, antibodies, or the recognised matrix proteins fibronectin, gelatin, laminin or matrigel.

An embodiment of the present invention will now be described, by way of example, with reference to the accompanying drawings, in which:

Figure 1 is a plan view of a sensor in accordance with the present invention;

Figure 2 is a perspective view of the sensor of Figure 1;

Figure 3 shows an alternative upper wall structure to that illustrated in Figures 1 and 2;

Figure 4 shows an alternative lower wall structure to that illustrated in Figures 1 and 2;

Figure 5 shows a side view of the wall structure of Figure 4; and

Figure 6 shows a further alternative upper wall structure.

Referring to Figures 1 and 2, the illustrated sensor comprises a base board 1 of for example ceramic or plastic onto which is adhered a single piece body defining eight wells between a first side wall 2, a rear wall 3, a second side wall 4, a front wall 5 and a partition wall 6. Each of the eight wells is open at its base so that the upper surface of the base board 1 is exposed within the well. The partition wall 6 defines four notches 7 each of which is located between a respective pair of wells. Thus in each pair it can be considered that there is a first working well adjacent the front wall 5, and a second reference well adjacent the rear wall 3, an opening being defined between the working and reference wells by the notch 7 in the partition wall 6 formed between the working and reference wells.

The board 1 has printed upon its upper surface an array of twelve working electrode contact strips 8 of for example copper. Printing may be effected using a conventional screen printing technique. These strips have portions 9 which extend beneath each of the working wells and terminate in circular end portions 10. A layer of gold is electrodeposited onto the copper (usually on top of a layer of nickel). Alternatively gold could be vapour deposited. The printed board beneath each of the working wells is then covered by an electrically insulating layer defining apertures 11 which expose central areas of the end portions 10 of the electrodes at the bottom of the working wells. The electrically insulating layer could be formed for example using a printable ceramic. Such a material may be biocompatible and provide a suitable surface for attachment of the well-defining body. A contact strip 12 is also printed on the board 1, that contact strip 12 being continuous with a reference electrode 13 which extends across each of the four reference wells defined between walls 3 and 6 of the structure. The reference electrode 13 could be for example of

silver/silver chloride. The strips, electrode surfaces and insulating layers may be formed in any convenient manner, for example using techniques used in the fabrication of printed circuit boards.

The board 1 and contact strips 8 and 12 are arranged such that the assembly can be plugged into a purpose built connector (not shown) so as to enable signals developed between any one of the working electrodes 11 and the common reference electrode 13 to be detected. In use, a culture medium would be introduced into each of the working wells so as to immerse the twelve electrodes 11. Biologically viable cells of interest would then be introduced into three of the four wells. The sensor would then be left undisturbed for a period sufficient for confluent cell layers to become established on the working electrodes. Confluent cell layers generate electrochemical signals which can be directly detected at the working electrode surface as described in US Patent No. 6010089, the cell layer in effect forming a barrier between the culture medium and the working electrode surface. Typically stable confluent cell layers will be established in a period of a few hours although it may be necessary to leave the cells undisturbed for a longer period, for example 24 hours, to enable the number of cells to increase as a result of cell division and to ensure that the cell layers have settled down.

The culture medium may be changed regularly, depending on cell type, and usually prior to any signal measurement or analysis, which may take place between several minutes to 48 hours after introduction of the culture medium. Fresh culture medium is introduced to a level just below that at which the culture medium would overflow from the working wells into the reference wells beneath which the reference electrode 13 extends.

Once the culture medium in the working wells has been carefully replaced, an aliquot of the same culture medium is introduced into the reference wells, immersing the electrode 13. Culture medium is introduced until it overflows the notches 7 in the partition walls 6, thereby establishing electrochemical continuity between the bodies of culture medium in the working and reference wells. Measurements of electrochemical activity at the surface of the working electrodes 11 can then be made by appropriate monitoring of signals generated between working electrodes 11 and the common reference electrode 12.

A working well filled with culture medium but into which no cells have been introduced provides a control with which the electrochemical signals generated in the other three working wells can be compared. Of the remaining three working wells, one may receive normal culture medium, another a cell stimulant, and the last could receive a cell suppressant. The electrochemical signals are then compared between the cell free control, the cells to which neither a suppressant or stimulant has been supplied, the cells which have been stimulated, and the cells which have been suppressed. A rapid assessment of cell activity can accordingly be derived. A microscope examination of the working electrodes could also be made to visually assess all layers formed on the working electrode. This may be facilitated by arranging for the walls to be removable, for example by securing the walls to the base using a weak adhesive; the adherent cells being visualised by, for example, incident-fluorescence microscopy.

In the illustrated case, three independent working electrodes are included in each of the working wells to provide statistically reliable data which can be compared with signals generated from the control well and other test wells.

In the illustrated example, a common reference electrode 13 extends along each of the second or reference wells. It would of course be possible to have separate reference electrodes exposed within each of the reference wells. In addition, it would be possible to have a common single reference well rather than the four separate wells as illustrated in Figures 1 and 2.

In some uses of the embodiment of Figures 1 and 2, extraneous electrical fields in the vicinity of the assembly may be picked up, making it difficult to distinguish between such unwanted signals and for example electrochemical noise signals generated by cells forming confluent layers on the electrodes. To reduce such unwanted signal pick-up, signal processing circuits such as pre-amplifiers may be built directly on the base board 1.

In the embodiment of Figures 1 and 2 electrical continuity between bodies of culture medium in the working and reference wells is achieved by providing direct communication between the two bodies of medium across the notches 7 in the partition wall 6. Such an arrangement will result in some degree of mixing between the culture media in the two adjacent wells. Although this does not generally



significantly affect the recorded signals, it is preferable to have the same culture media (and chemical or drug supplements) in the adjacent test and reference wells. Potential mixing of culture media could be prevented however if the notches 7 were filled by a material which would maintain electrochemical continuity, by allowing the exchange of ions and amino acids for example, but would prevent the exchange of larger molecules such as proteins, hormones, ligands or many synthetic drugs. A molecular weight cut off of for example 400 daltons would be appropriate.

Figure 3 illustrates an alternative arrangement for achieving electrochemical continuity between working and reference wells. Rather than relying upon a notch 7 in a partition wall 6, absorbent strip 14 extends over the top of the partition wall 6 so that the ends of the strip 14 would be immersed in the culture medium introduced into the working and reference wells. Culture medium absorbed into the strip 14 would then provide the necessary electrochemical continuity.

Figures 4 and 5 show an alternative arrangement for establishing electrical continuity between the working and reference wells. In the case of Figure 4, the partition wall 6 is secured to the base 1 by an adhesive 15, the adhesive 15 performing two functions, that is securing the wall 6 to the base 1 and providing a path for ion exchange whilst preventing leakage of culture medium and its larger sized constituents from the working to the reference well. As shown in Figure 5, the base of the working well/reference well partition wall may be serrated to facilitate electrochemical continuity between the two wells.

Figure 6 shows an alternative arrangement for achieving electrochemical continuity between working and reference wells. In this example, an opening 16 through the partition wall 6 is sized such that growth medium will wet the inner wall of the opening but not flow through because of the effect of surface tension. Culture medium introduced into the reference well will make an electrochemical connection with the meniscus formed within the partitioning wall opening.

When culture medium incorporating cells is left for a prolonged period to settle, cellular activity may change the pH value of the medium. To stabilise the pH value, the sensor may be maintained within a suitable controlled atmosphere, for example a 5% carbon dioxide plus air mixture, this being a conventional cell culture requirement.

In the embodiment of the invention illustrated in Figures 1 and 2, four pairs of working and reference wells are provided in a linear array. It will be appreciated that any convenient number of working cells with either respective reference cells, or a single common reference cell could be provided. It will also be appreciated that the working cells do not have to be arranged in a linear array. For example, a single common central reference well could be provided with working wells arranged there around, a single annular wall separating the working wells from the reference well. The single annular wall would be formed so as to enable the establishment of electrical continuity between a reference electrode immersed in a culture medium within the reference well and each of a series of bodies of culture medium in each of the working wells. A further well may also be provided to receive a representative sample of the cells under investigation, the further well having a relatively large exposed electrode surface structurally identical to each of the working electrode surfaces exposed in the normal working wells. The relatively large additional electrode surface could then be inspected using for example a microscope to assess the degree to which cells have established a confluent layer.

Although in the illustrated embodiment, three working electrodes are provided in each working well, it would be possible to provide only a single working electrode per working well or to provide two or more than three working electrodes per well.

The exposed surface area of each working electrode could be relatively small, for example a circular area of 0.5mm to 1.0mm diameter or less. The smaller the exposed area, the easier it will be to establish cell confluence. Although gold is the preferred surface metal for the working electrodes, other materials could be used, for example platinum. Platinum however is relatively responsive to fluctuations in pH value whereas the resting potential of gold electrodes appears to be almost unaffected by changes in temperature, serum protein and oxygen concentrations.

CLAIMS

1. An electrochemical sensor comprising at least one first well for receiving a sample of culture medium containing biological cells, a working electrode a portion of which is exposed within the first well and is capable of supporting a layer of biological cells, and at least one second well located adjacent the first and separated therefrom by a wall, the wall being arranged such that, if the first well is filled with an electrochemically conductive culture medium to a first predetermined level sufficient to immerse the working electrode and the second well is filled with an electrochemically conductive culture medium to a second predetermined level, electrochemical continuity is established between the bodies of liquid within the first and second wells, whereby electrochemical signals generated by cells on the working electrode may be detected by monitoring signals generated between the working electrode and the liquid within the second well.
2. A sensor according to claim 1, comprising a reference electrode exposed within the or each second well below the second predetermined level.
3. A sensor according to claim 2, comprising a plurality of second wells and a single reference electrode extending along the bottom of each second well.
4. A sensor according to claim 1, 2 or 3, wherein the wall defines an opening below the first and second predetermined levels such that bodies of liquid filling the wells to the predetermined levels are in contact through the opening.
5. A sensor according to claim 4, wherein the opening is defined by a notch formed in an upper edge of the wall.
6. A sensor according to claim 1, 2 or 3, wherein the wall defines an upper edge above the first and second predetermined wall levels, a liquid and ion-absorbent material extending over the wall upper edge from below the first predetermined level

in the first well to below the second predetermined level in the second well to provide electrochemical continuity.

7. A sensor according to claim 1, 2 or 3, wherein the wall defines an upper edge above the first and second predetermined levels, the wall including an ion permeable portion exposed in the first well beneath the first predetermined level and in the second well beneath the second predetermined level.
8. A sensor according to claim 7, wherein the wall has a lower edge secured to a base by adhesive, the adhesive defining the ion-permeable portion of the wall.
9. A sensor according to any preceding claim, comprising an array of first wells each separated from a respective second well by a respective wall.
10. A sensor according to any one of claims 1 to 8, comprising an array of first wells each separated from a single common second well by a respective wall.
11. A sensor according to any preceding claim, wherein the or each first cell is provided with a plurality of working electrodes.
12. A sensor according to any preceding claim, wherein the or each exposed working electrode portion is located at the base of a recess defined by an opening in an insulating layer at the bottom of the first well.
13. A method for monitoring signals generated by biological cells, wherein a layer of cells is formed on an exposed portion of a working electrode located within a first sensor well, the first well and an adjacent second well are filled to respective first and second predetermined levels with an electrochemically conductive culture medium, the wells being arranged such that electrochemical continuity is established between the bodies of culture medium in the first and second wells, and electrochemical cell activity is detected by monitoring signals appearing between the working electrode and a reference electrode in contact with culture medium in the second well.

14. A method according to claim 13, wherein the layer of cells is formed by introducing cells into the first well in a culture medium, and leaving the culture medium in the first well until a layer of cells is formed over the exposed portion of the working electrode, and cell activity is detected by monitoring signals after filling the second well to the second predetermined level with the culture medium.

15. A method according to claim 14, wherein the layer of cells adheres to the exposed portion of the working electrode, and cell activity is detected by monitoring signals after the culture medium within the first well is removed and then replaced with fresh culture medium.

16. An electrochemical sensor substantially as hereinbefore described with reference to Figures 1 and 2, 3, 4, 5 or 6 of the accompanying drawings.

17. A method for monitoring signals generated by a biological cell substantially as hereinbefore described with reference to the accompanying drawings.

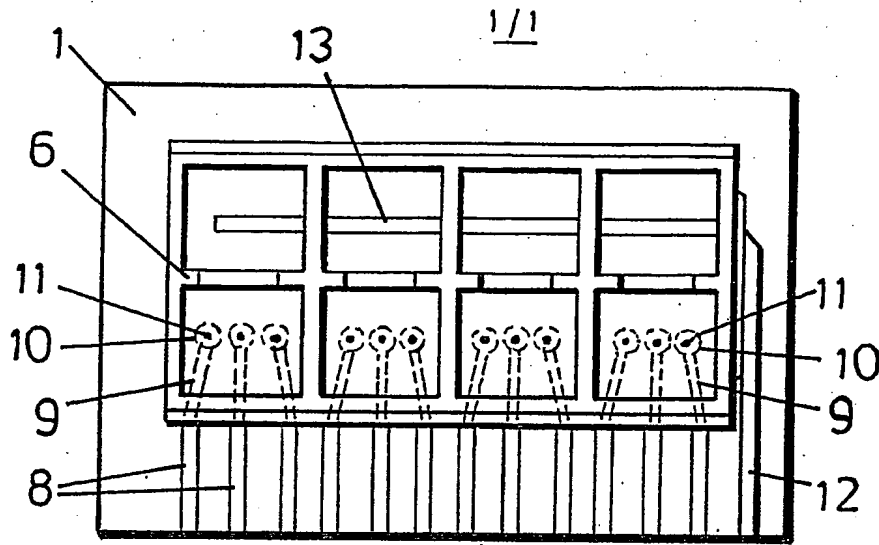

FIG. 1

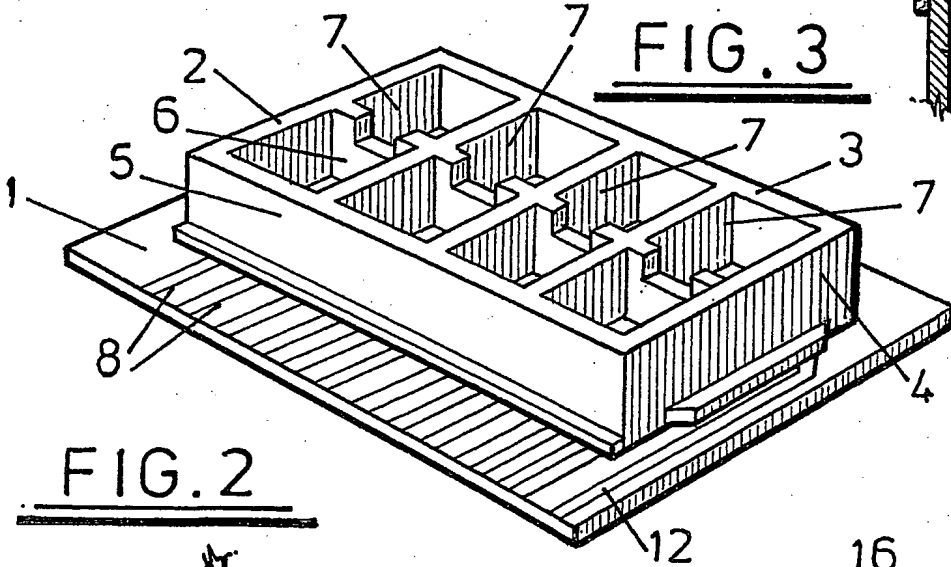

FIG. 2

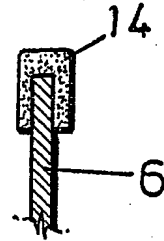

FIG. 3

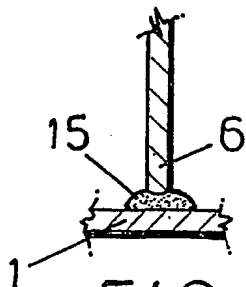

FIG. 4

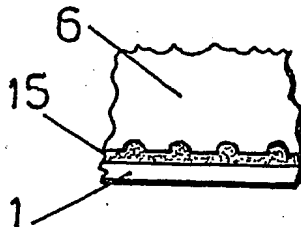

FIG. 5

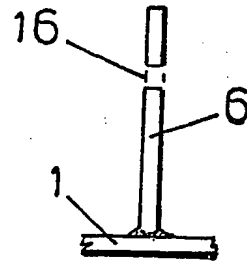

FIG. 6

INTERNATIONAL SEARCH REPORT

Intern: Application No  
PCT/GB 01/01829

**A. CLASSIFICATION OF SUBJECT MATTER**  
IPC 7 G01N33/487 G01N33/50 C12M1/34

According to International Patent Classification (IPC) or to both national classification and IPC

**B. FIELDS SEARCHED**  
Minimum documentation searched (classification system followed by classification symbols)  
IPC 7 G01N C12M

Documentation searched other than minimum documentation to the extent that such documents are included in the fields searched

Electronic data base consulted during the international search (name of data base and, where practical, search terms used)  
EPO-Internal, WPI Data, PAJ, BIOSIS

**C. DOCUMENTS CONSIDERED TO BE RELEVANT**

Category *	Citation of document, with indication, where appropriate, of the relevant passages	Relevant to claim No.
Y	US 6 010 889 A (EDEN ROBERT DAVID ET AL) 4 January 2000 (2000-01-04) cited in the application the whole document	1-3,9, 11,13, 16,17
Y	WO 96 15450 A (SARNOFF DAVID RES CENTER) 23 May 1996 (1996-05-23)  page 1 -page 9	1-3,9, 11,13, 16,17
A	US 4 225 410 A (PACE SALVATORE J) 30 September 1980 (1980-09-30) the whole document	1-17
A	US 4 963 245 A (WEETALL HOWARD H) 16 October 1990 (1990-10-16) the whole document	1-17
	-/--	

Further documents are listed in the continuation of box C.  Patent family members are listed in annex.

\* Special categories of cited documents :

*A* document defining the general state of the art which is not considered to be of particular relevance	*T* later document published after the international filing date or priority date and not in conflict with the application but cited to understand the principle or theory underlying the invention
*E* earlier document but published on or after the international filing date	*X* document of particular relevance; the claimed invention cannot be considered novel or cannot be considered to involve an inventive step when the document is taken alone
*L* document which may throw doubts on priority claim(s) or which is cited to establish the publication date of another citation or other special reason (as specified)	*Y* document of particular relevance; the claimed invention cannot be considered to involve an inventive step when the document is combined with one or more other such documents, such combination being obvious to a person skilled in the art.
*O* document referring to an oral disclosure, use, exhibition or other means	* & * document member of the same patent family
*P* document published prior to the international filing date but later than the priority date claimed	

Date of the actual completion of the international search  1 October 2001	Date of mailing of the international search report  22/10/2001
---	--

Name and mailing address of the ISA European Patent Office, P.B. 5818 Patentlaan 2 NL - 2280 HV Rijswijk Tel. (+31-70) 340-2040, Tx. 31 651 epo nl, Fax: (+31-70) 340-3016	Authorized officer  Joyce, D
--	------------------------------------

INTERNATIONAL SEARCH REPORT

International Application No  
PCT/GB 01/01829

C.(Continuation) DOCUMENTS CONSIDERED TO BE RELEVANT		
Category *	Citation of document, with indication, where appropriate, of the relevant passages	Relevant to claim No.
A	WO 99 67628 A (LUMLEY WOODYEAR THIERRY DE ;HELLER ADAM (US); HELLER E & CO (US);) 29 December 1999 (1999-12-29) page 1 -page 15 -----	1-17



## INTERNATIONAL SEARCH REPORT

Information on patent family members

International Application No

PCT/GB 01/01829

Patent document cited in search report		Publication date	Patent family member(s)	Publication date
US 6010889	A	04-01-2000	AU 3571195 A	26-04-1996
			EP 0783690 A1	16-07-1997
			WO 9610742 A1	11-04-1996
			GB 2307990 A , B	11-06-1997
WO 9615450	A	23-05-1996	US 5585069 A	17-12-1996
			AU 705351 B2	20-05-1999
			AU 4152396 A	06-06-1996
			AU 705659 B2	27-05-1999
			AU 4233796 A	06-06-1996
			CA 2204912 A1	23-05-1996
			CA 2205066 A1	23-05-1996
			EP 0791238 A1	27-08-1997
			EP 0808456 A1	26-11-1997
			JP 11500602 T	19-01-1999
			WO 9615450 A1	23-05-1996
			WO 9615576 A1	23-05-1996
			US 5681484 A	28-10-1997
			US 5643738 A	01-07-1997
			US 5593838 A	14-01-1997
			US 5846396 A	08-12-1998
			US 5985119 A	16-11-1999
			US 5755942 A	26-05-1998
			US 5863708 A	26-01-1999
			US 5858804 A	12-01-1999
US 4225410	A	30-09-1980	CA 1136701 A1	30-11-1982
			DE 2963565 D1	14-10-1982
			EP 0012035 A1	11-06-1980
US 4963245	A	16-10-1990	US 5066372 A	19-11-1991
WO 9967628	A	29-12-1999	AU 4833899 A	10-01-2000
			EP 1090286 A1	11-04-2001
			WO 9967628 A1	29-12-1999

**This Page Blank (uspto)**

**This Page is Inserted by IFW Indexing and Scanning  
Operations and is not part of the Official Record**

**BEST AVAILABLE IMAGES**

Defective images within this document are accurate representations of the original documents submitted by the applicant.

Defects in the images include but are not limited to the items checked:

- BLACK BORDERS**
- IMAGE CUT OFF AT TOP, BOTTOM OR SIDES**
- FADED TEXT OR DRAWING**
- BLURRED OR ILLEGIBLE TEXT OR DRAWING**
- SKEWED/SLANTED IMAGES**
- COLOR OR BLACK AND WHITE PHOTOGRAPHS**
- GRAY SCALE DOCUMENTS**
- LINES OR MARKS ON ORIGINAL DOCUMENT**
- REFERENCE(S) OR EXHIBIT(S) SUBMITTED ARE POOR QUALITY**
- OTHER:** \_\_\_\_\_

**IMAGES ARE BEST AVAILABLE COPY.**

**As rescanning these documents will not correct the image problems checked, please do not report these problems to the IFW Image Problem Mailbox.**

**This Page Blank (uspto)**